

- NOTES :
- MATERIAL :
    - HOUSING:LCP UL94 V-0, BLACK COLOR.
    - SHELL:STAINLESS STEEL.
    - CONTACT:COPPER ALLOY.
  - FINISH :
    - CONTACT: GOLD PLATING ON CONTACT AREA, MATTE TIN 100u"MIN ON SOLDERTAIL AREA. 50u" MIN NICKEL PLATING OVERALL.
    - SHELL: 30U" MIN SOLDERABLE NICKEL PLATED OVER ALL.
  - ELECTRICAL CHARACTERISTICS:
    - OPERATING VOLTAGE : 100V AC(rms)/DC.
    - CURRENT RATING : 0.5 A.
    - OPERATING TEMPERATURE: -25°C~+85°C.
    - CONTACT RESISTANCE: 100 m OHMS MAX.
    - INSULATION RESISTANCE: 1000M OHMS MIN. AT 250VDC.
    - DIELECTRIC WITHSTANDING VOLTAGE:500 VAC/1MINUTE.

PART.NO.: TW62-AP401-\*\*\*

42: 功能区镀金10u", 锡脚镀纯锡至少100u"  
 43: 功能区镀金30u", 锡脚镀纯锡至少100u"  
 44: 功能区镀金50u", 锡脚镀纯锡至少100u"  
 45: 功能区镀金100u", 锡脚镀纯锡至少100u"  
 46: 功能区镀金150u", 锡脚镀纯锡至少100u"  
 47: 功能区镀金300u", 锡脚镀纯锡至少100u"

GENERAL TOLERANCE	DWG.NO.	TW62-AP401-00	PART.NO.	TW62-AP401-***	DRAWN	L.M.J 2015.10.05
x.±0.50	REV.	A	TITLE	SD4.0 Push H3.10 Conn.	CHECKED	
.x±0.25	SIZE	A4	SHEET	1 OF 4	APPROVED	
.xx±0.15						

UNIT	mm	SCALE	1:1
<b>东莞市欧联电子科技有限公司</b> DONGGUAN OLN ELECTRONICS TECHNOLOGY CO., LTD.			

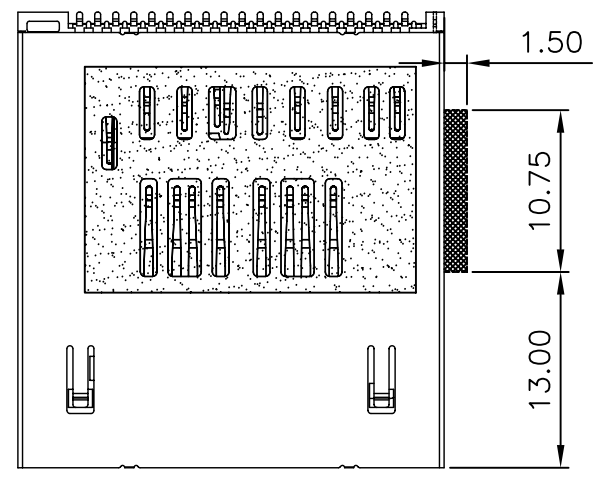
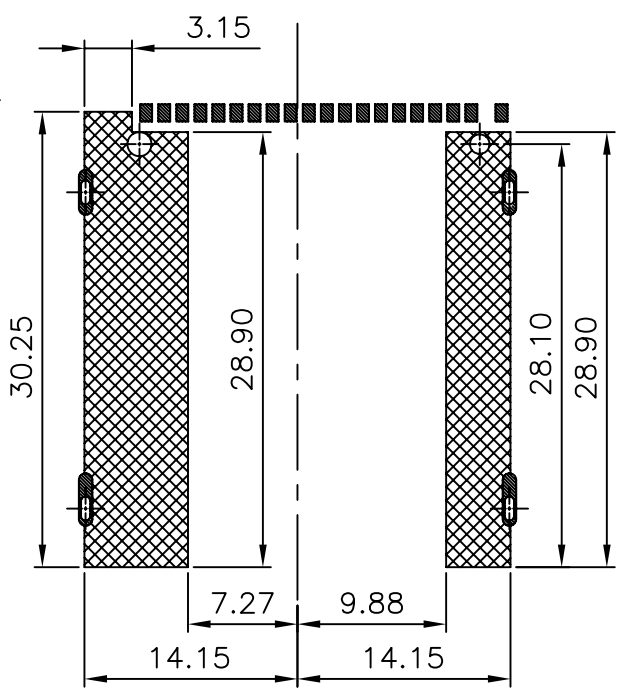
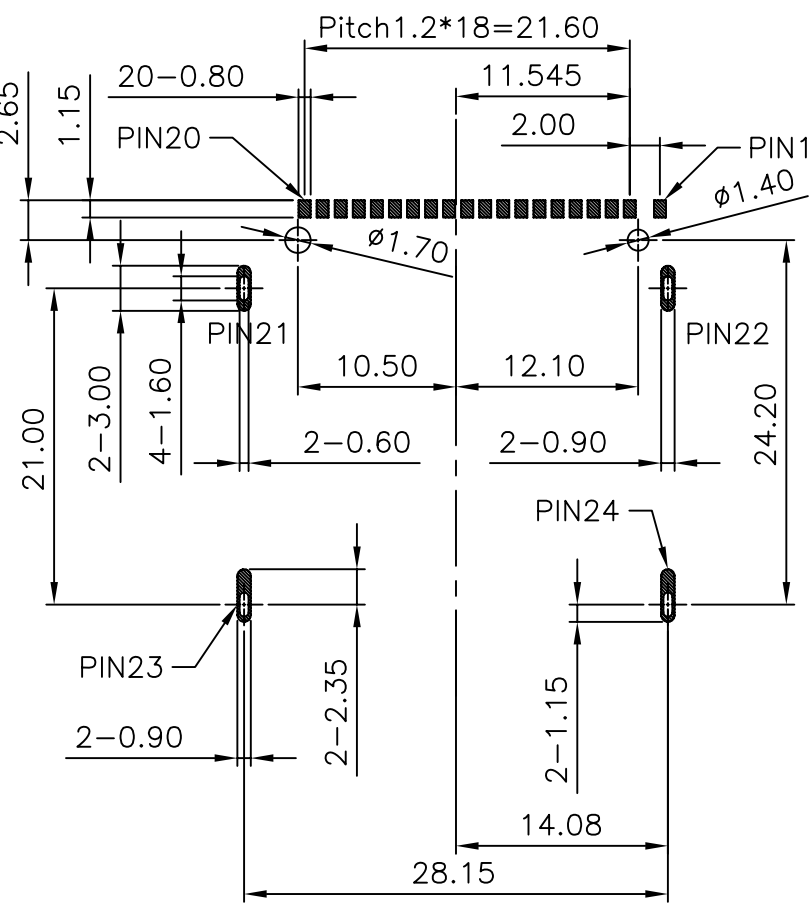

NO COMPONENT AREA

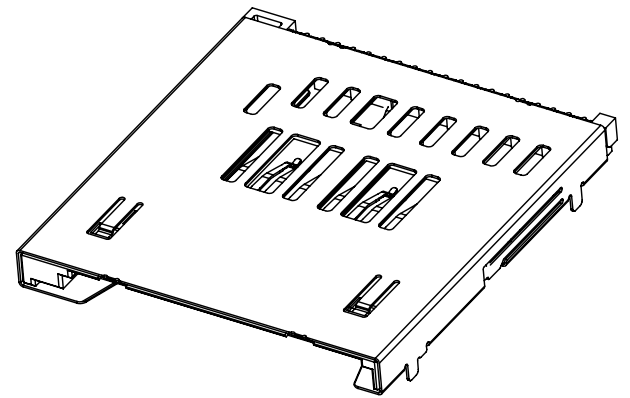

RECOMMEND P.C.B LAYOUT  
TOLERANCE ±0.05

- PAD
- NO TRACE , NO TEST POINT,  
NO VIA HOLE, NO GROUND AREA

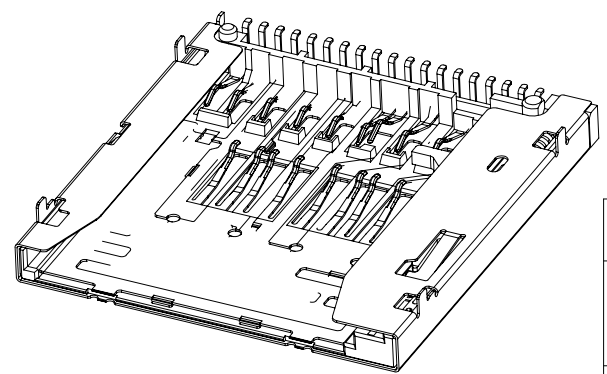

WITHOUT CARD		CARD INSERTED:LOCK		CARD INSERTED:UNLOCK	
C/D #12	VSS1 #11	C/D #12	VSS1 #11	C/D #12	VSS1 #11
WP #1	GND #21~24	WP #1	GND #21~24	WP #1	GND #21~24

GENERAL TOLERANCE	DWG.NO.	TW62-AP401-00	PART.NO.	TW62-AP401-**	DRAWN	L.M.J 2015.10.05
x.±0.50	REV.	A	TITLE	SD4.0 Push H3.10 Conn.	CHECKED	
.x±0.25	SIZE	A4	SHEET	2 OF 4	APPROVED	
.xx±0.15						

UNIT	mm	SCALE	1:1
<b>OLN</b> 东莞市欧联电子科技有限公司 DONGGUAN OLN ELECTRONICS TECHNOLOGY CO., LTD.			

# Pin Define

Connector PinNo.	Specifications SD4.0 PinNo.	Specifications MMC PinNo.	SD Mode			UHS-II Mode			MMC		
			Name	Type	Description	Name	Type	Description	Name	Type	Description
P1			WP			WP					
P2	P8		DAT1	I/O/PP	Data Line[Bit 1]	RCLK-	I				
P3	P7	P7	DAT0	I/O/PP	Data Line[Bit 0]	RCLK+	I		DAT	I/O/PP	Data
P4	P17		—		Not Used(Connected to ground)	VSS5	S	Supply voltage ground			
P5	P6	P6	VSS2	S	Supply voltage ground	VSS2	S	Supply voltage ground	VSS	S	Supply voltage ground
P6	P16		—		Not Used	D1+	LVDS				
P7	P5	P5	CLK	I	Clock	—		Not Used	CLK	I	Clock
P8	P15		—		Not Used	D1-	LVDS				
P9	P4	P4	VDD	S	Supply voltage	VDD1	S	Supply voltage(3.3V)	VDD	S	Supply voltage
P10	P14		—		Not Used	VDD2	S	Supply voltage(1.8V)			
P11	P3	P3	VSS1	S	Supply voltage ground	VSS1	S	Supply voltage ground	VSS	S	Supply voltage ground
P12			CD			CD					
P13	P13		—		Not Used(Connected to ground)	VSS4	S	Supply voltage ground			
P14	P2	P2	CMD	PP	Command/Response	—		Not Used	CMD	I/O/PP/OD	Command/Reserved
P15	P12		—		Not Used	D0-	LVDS				
P16	P1	P1	CD/DAT3	I/O/PP	Card Detect/ Data Line[Bit 3]	—		Not Used	RSV	NC	Reserved for future use
P17	P11		—		Not Used	D0+	LVDS				
P18	P9		DAT2	I/O/PP	Data Line[Bit 2]	—					
P19	P10		—		Not Used(Connected to ground)	VSS3	S	Supply voltage ground			
P20			GND			GND			GND		
P21			GND			GND			GND		
P22			GND			GND			GND		
P23			GND			GND			GND		
P24			GND			GND			GND		

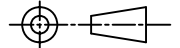
GENERAL TOLERANCE	DWG.NO.	TW62-AP401-00	PART.NO.	TW62-AP401-**	DRAWN	L.M.J 2015.10.05	UNIT	mm	SCALE	1:1
x.±0.50	REV.	A	TITLE	SD4.0 Push H3.10 Conn.	CHECKED		 <b>OLN</b> 东莞市欧联电子科技有限公司 DONGGUAN OLN ELECTRONICS TECHNOLOGY CO., LTD.			
.x±0.25	SIZE	A4	SHEET	3 OF 4	APPROVED					
.xx±0.15	A4									

REV.	ECN.NO.	MODIFY.CONTENT
------	---------	----------------

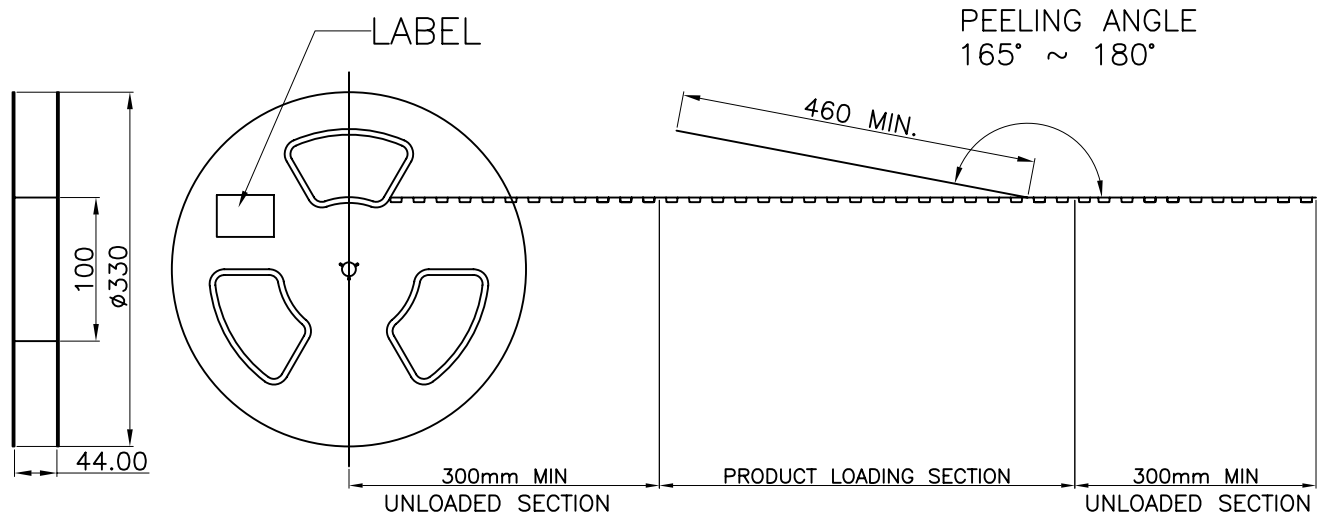

- NOTES :
- MATERIAL :  
 COVER TAPE : P.S  
 CARRIER TAPE : P.S  
 REEL : PS UL94V-0  
 CARTON: CORRUGATED FIBER
  - DIMENSION :  
 REEL : SEE DRAWING  
 SHIPPING BOX: 350X350X310mm
  - QUANTITY : SEE TABLE
  - PEELING RESISTANCE : 10gf~130gf (for 12~56mm)
  - PEELING SPEED : 300mm/MINUTES

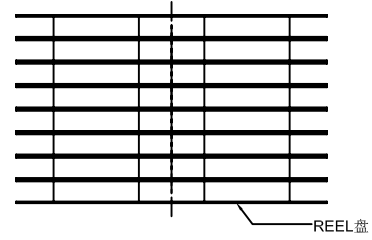

PULL OUT DIRECTION

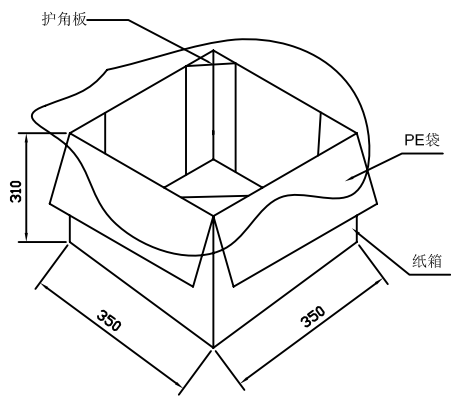
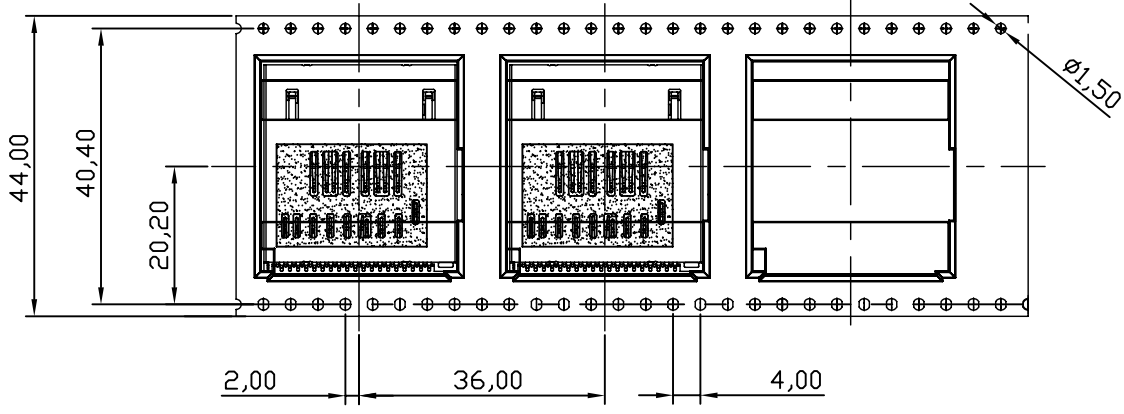

300	6	1800
PCS/REEL	REEL/BOX	TOTAL Q' TY

GENERAL TOLERANCE	DWG.NO.	TW62-AP401-00	PART.NO.	TW62-AP401-**	DRAWN	L.M.J 2015.10.05
x.±0.50	REV.	A	TITLE	SD4.0 Push H3.10 Conn.	CHECKED	
.x±0.25	SIZE	A4	SHEET	4 OF 4	APPROVED	
.xx±0.15	A4					

UNIT	mm	SCALE	1:1
<b>OLN</b> 东莞市欧联电子科技有限公司 DONGGUAN OLN ELECTRONICS TECHNOLOGY CO., LTD.			